



HI-EFFICIENCY BATTERY CHARGER



SBC-10A-M

12/24V AUTOSELECT

10.0 AMPERES

4 STAGES

90-300 VAC

DESCRIPTION

SBC-10A-M series are state of the art battery chargers featuring very high efficiency and low cost in a compact metallic casing.

Chargers are designed to withstand high levels of disturbances found in the harsh automotive environment.

Chargers are practically impossible to destroy, having overload, short circuit, high temperature and reverse battery protections. The overload protection is current limiting type, not hiccup. Hiccup protected chargers will turn-off in case of overload and will be incapable of charging an empty battery with their rated current. In case of a short circuit or overload condition, the SBC-10A-M charger does not shut-off and delivers simply the rated current, allowing a full-speed charge of an empty battery.

In case of overheating, the charger will automatically reduce its output current and continue normal operation.

Chargers offer automatic battery voltage detection. Thus, the same module operates at 12V or 24V without the need of a manual selection, removing human errors.

SBC-10A-M chargers have universal input voltage range, enabling the use in all countries with nominal voltages ranging from 110VAC to 277VAC. The nominal output is fully available at all 90-300VAC range without derating.

Chargers offer green mode of operation. The green mode consists on reducing the operating frequency when the load decreases. Thus, chargers reduce their losses helping protection of the environment. At very small loads, they enter into a burst mode to reduce the consumption further.

Chargers feature very low power consumption at no-load mode, helping again the protection of the environment.

The peak efficiency reaches 92.5%, resulting in lower long-term operational costs. As an example, compared to a 24V/10A charger of 85% efficiency, with 30% average load and 20 years of operational life, SBC-10A-M will consume 1350 kW-hour less electrical energy. This leads to 135USD less energy expense per charger.

The rectifier fail output is capable of driving a relay or transmitting the operational status to a control module which will give an alarm in case of failure.

FEATURES

- **Very high efficiency, up to 92.5% (see charts)**
- **Wide operating voltage range (90-300VAC)**
- **Reverse battery connection protected**
- **LED status indicator**
- **Low power consumption at zero-load**
- **Green mode operation**
- **Output short circuit and overload protection**
- **High temperature protection**
- **Up to 4 stage charging with smart control**
- **Easy to use, DIP switch selections**
- **Battery life extending regenerative charging**
- **Two, three or four stage charging selections**
- **Supports lead-acid, Li-Ion and Ni-Cd batteries**
- **Rectifier fail output**
- **Analog 0-5V current measuring output**
- **Wide operating temperature range**
- **Low output ripple & noise**
- **Low line and load regulations**
- **DIN rail mounted, small dimensions**
- **Low weight**



CE EAC RoHS

COPYRIGHT NOTICE

Any unauthorized use or copying of the contents or any part of this document is prohibited. This applies in particular to trademarks, model denominations, part numbers and drawings.

ABOUT THIS DOCUMENT

This document describes the minimum requirements and necessary steps for the successful installation of BC and SBC series of battery chargers.

Follow carefully advices given in the document. These are often good practices for the installation of battery chargers which reduce future issues.

For all technical queries, please contact Datakom at the e-mail address below:

technical.support@datakom.com.tr

QUERIES

If additional information to this manual is required, please contact the manufacturer directly at:

technical.support@datakom.com.tr

Please provide the following information in order to receive answers to any question:

- Device model name
- Device serial number (see back panel),
- Mains supply voltage and frequency,
- Precise description of the query.

REVISION HISTORY

REVISION	DATE	AUTHOR	DESCRIPTION
01	28.09.2021	MH	First Edition

TERMINOLOGY



CAUTION: Potential risk of injury or death.



WARNING: Potential risk of malfunction or material damage.



ATTENTION: Useful hints for the understanding of device operation.

**SAFETY NOTICE**

Failure to follow the following instructions may result in death or serious injury.



Electrical equipment should be installed only by a qualified specialist. No responsibility is assumed by the manufacturer or any of its subsidiaries for any consequences resulting from non-compliance to these instructions.



Read this manual carefully before installation.



Check the module for cracks and damages due to transportation. Do not install damaged equipment.



Any electrical parameter applied to the device must be within the range specified in the user manual. Over-range parameters may reduce lifetime or even damage the battery charger.



Do not open the battery charger. There are no serviceable parts inside.



Fuses of fast type with a maximum rating of 6A must be connected to supply inputs and DC outputs of the battery charger.



Disconnect all power before working on the equipment.



Verify correct terminal connections before applying power.



Do not touch the terminals when the controller is connected to the power grid.



The battery charger is designed to be mounted inside an electrical panel and should not be used as a standalone product.

TABLE OF CONTENTS

1. INSTALLATION INSTRUCTIONS
2. MOUNTING
3. VOLTAGE DROP IN CABLES
4. REVERSE BATTERY PROTECTION
5. OVERLOAD / SHORT CIRCUIT PROTECTION
6. HIGH TEMPERATURE PROTECTION
7. NO-LOAD OPERATION
8. OPERATION AT LOW INPUT VOLTAGE
9. OPERATION AT HIGH INPUT VOLTAGE
10. COOLING
11. AUTOMATIC POWER DERATING
 - 11.1. EFFECT OF BLOCKING THE AIRFLOW
 - 11.2. OPERATION AT HIGH AMBIENT TEMPERATURES
12. POWER DISSIPATION, EFFICIENCY
 - 12.1. EFFECT OF SUPPLY VOLTAGE
13. WIRING DIAGRAM
14. TECHNICAL SPECIFICATIONS
15. CURRENT CONSUMPTION FROM BATTERY
16. AUTO SELECT OPERATION
17. PARALLEL OPERATION
18. SERIES OPERATION
19. CONSTANT VOLTAGE, LIMITED CURRENT OPERATION
20. TWO STAGE CHARGING
21. FOUR STAGE CHARGING, SMART CHARGING
22. BATTERY TYPE SELECTION
23. DIP SWITCH SETTINGS
24. STATUS INDICATOR
25. FAIL OUTPUT
26. ANALOG OUTPUT
27. DECLARATION OF CONFORMITY
28. MAINTENANCE
29. DISPOSAL OF THE UNIT
30. ROHS COMPLIANCE
31. TROUBLESHOOTING

1. INSTALLATION INSTRUCTIONS

Before installation:

- Read the user manual carefully; determine the correct connection diagram.
- Remove all connectors from the module, then install the module.
- Make electrical connections with plugs removed from sockets, then place plugs into their sockets.
- Be sure that adequate cooling is provided.
- Be sure that the temperature of the environment will not exceed the maximum operating temperature in any case.

Below conditions may damage the device:

- Incorrect connections.
- Incorrect power supply voltage.
- Overload or short circuit at signal outputs.
- Voltage applied at signal outputs.
- Excessive vibration, direct installation on vibrating parts.



The battery charger is designed to be vertically mounted inside an electrical panel and should not be used as a standalone product.

Below conditions may cause abnormal operation:

- Power supply voltage below minimum acceptable level.
- Power supply frequency out of specified limits.
- Blocked airflow, not enough free space left around the device.
- Device not mounted vertically.

2. MOUNTING

Dimensions: 106mm(W) x 115mm(H) x 57mm(D)

Screws: 4xM5 (73x98mm)

Weight (approx): 320 grams



The unit is designed for bolt and stud mounting inside an enclosed panel.

It cannot be used as a stand-alone product.



The user should not be able to access the unit without the use of a tool.

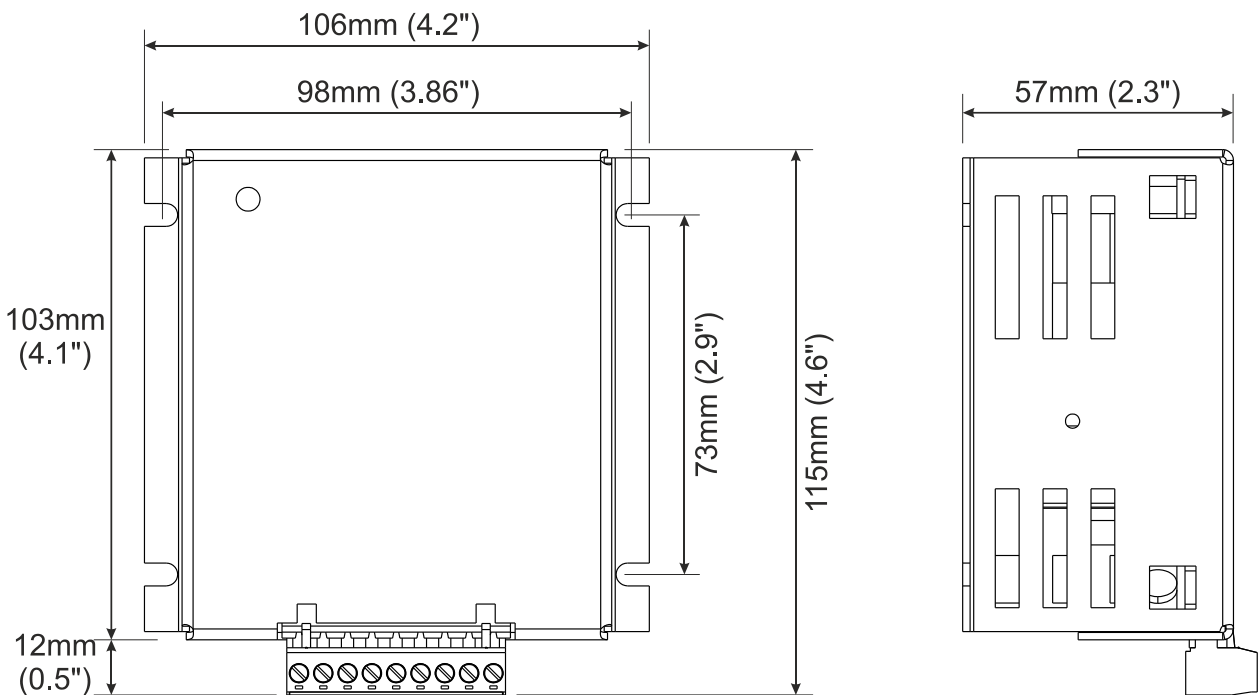

Mount the unit on a flat, vertical surface.

3. VOLTAGE DROP IN CABLES

Current flowing in a conductor will cause a voltage drop. This voltage drop will reduce the charging speed of the device and should be taken into account during the panel design.

For a voltage drop of **0.5V** in cables, below table shows the maximum cable length that may be used:

CABLE SECTION	5 Amperes	7 Amperes	10 Amperes
0.75 mm ²	1.90m	1.30m	0.85m
1.00 mm ²	2.50m	1.80m	1.25m
1.50 mm ²	3.75m	2.70m	1.90m
2.50 mm ²	6.25m	4.50m	3.10m
4.00 mm ²	10.00m	7.10m	5.00m



The voltage drop in cables will reduce the charging performance. Always use a cable of the right section.



Do not increase the float voltage because of voltage drop in cables! You can damage the battery.

4. REVERSE BATTERY PROTECTION

The charger is protected against reverse battery connection.

The protection is performed through a N-channel mosfet transistor used as a power switch.

The reverse battery protection circuit opens the transistor in case of reverse polarity detected at charger output terminals, protecting the internal circuit from a possible damage.

The transistor opens the output fast enough to protect any internal component, thus, a reverse battery may be even connected during charger operation without any harm.

5. OVERLOAD / SHORT CIRCUIT PROTECTION

If a current superior to the nominal output current (I_o) of the charger is requested, the charger will react by reducing its output voltage and sourcing its nominal current only.

The overload protection is current limiting type, not hiccup. Hiccup protected chargers will turn-off in case of overload and will be incapable of charging an empty battery with their rated current. In case of a short circuit or overload condition, SBC/BC chargers do not shut-off, and deliver simply the rated current, allowing a full-speed charge of an empty battery.

In case of overload condition, as the voltage is less than its nominal value, the output power will be less than the maximum output power.

The overload condition can continue indefinitely without any damage to the charger.

In case of a neat short-circuit, the charger will limit its output current to a value slightly superior to its nominal current (I_o).

In short circuit condition, the output power sourced by the charger is very small. The short circuit condition can be maintained endlessly without any harm to the charger.

6. HIGH TEMPERATURE PROTECTION

The internal temperature sensor will limit the temperature of the circuit to **T_{max}** which is 85 degrees C (185 degrees F).

If the charger overheats up the T_{max} value, then the output power will be reduced so that the charger produces less heat and the temperature stays at T_{max} value.

The design limit temperature of the charger is 105 degrees C (221 degrees F). Thus, T_{max} value is set with a large safety margin and the effect of high temperature will have very limited effect on the lifetime of the charger.

The high temperature protection allows the charger to operate **with limited capacity** in below conditions:

- At very high ambient temperatures up to 80 degrees C (176 degrees F)
- In panels where the airflow is strongly obstructed.

7. NO LOAD OPERATION

The charger has state-of-the-art green design allowing operation at zero-load condition with a very low power consumption from the mains.

The nominal output voltage is maintained even without load. Thus, the charger can function as a DC power supply as well.

Compared to a typical charger consuming 3W at no-load condition, this charger will consume 25kWh less energy per year. This corresponds to 2.50USD less energy expenses per year. In its operational life of 20 years, one charger will consume 50 USD less energy than a typical charger.

8. OPERATION AT LOW INPUT VOLTAGE

If the charger is forced to operate with an input voltage lower than its lower limit, it will operate with limited power output capacity.

Low input voltage condition is not harmful to the charger.

9. OPERATION AT HIGH INPUT VOLTAGE

If the charger is forced to operate with an input voltage higher than its upper limit, it will operate with full capacity, but most probably will get damaged very fast.



Do not apply high voltage to the charger. This will cause permanent damage and is out of warranty.

10. COOLING

During its operation, the charger produces heat energy, which will heat the air inside the module.

BC and SBC series battery chargers are cooled through the “natural convection” method.

Hot air is lighter than cold air and will move upwards, making space for cold air entering from the lower part of the enclosure. Thus, heat energy is transferred to the external world by the hot air moving upwards.

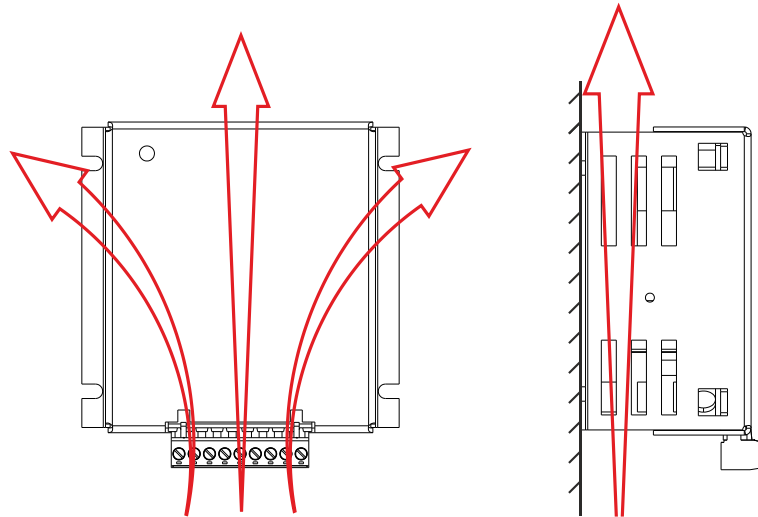

HOT AIR MOVEMENTS INSIDE A CHARGER

Providing adequate cooling is essential for the correct operation of the device. Blocking airflow will cause the device to heat-up prematurely and the performance will drop.

However, blocking airflow will not cause failure, thanks to the internal high temperature protection.

In order to allow airflow, always provide at least 5cm (2.0”) of free air space in all directions from the unit.

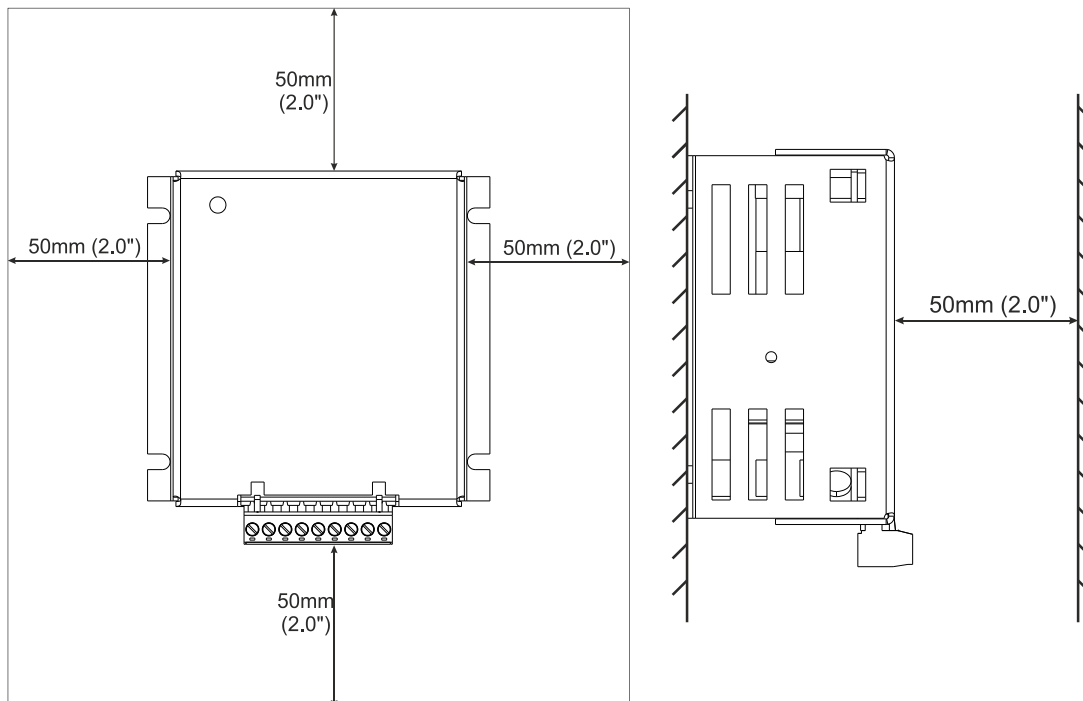

11. AUTOMATIC POWER DERATING

The internal temperature of the charger is limited to T_{max} of 85°C (185°F) by the high temperature protection circuit. If the internal temperature reaches the limit, the circuit will reduce the output current accordingly. Thus, the battery charger will continue operation until the ambient temperature reaches the T_{max} limit.

Below graph shows the amount of available power in function of the ambient temperature, in case of free airflow installation.

As the efficiency is lower at low voltage input, the power derating starts earlier in this case.

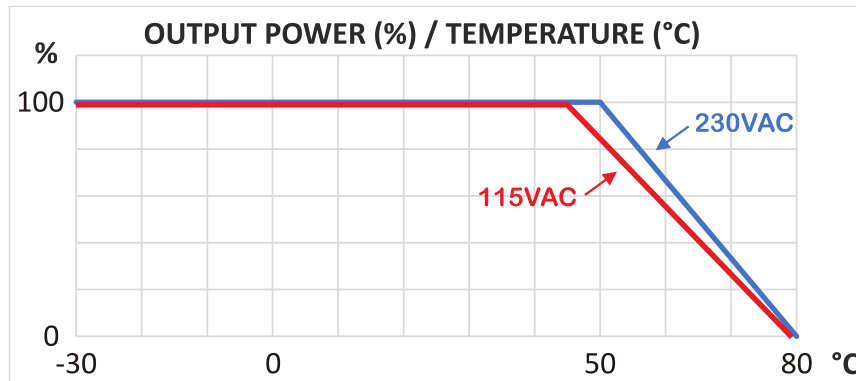

11.1. EFFECT OF BLOCKING THE AIRFLOW

Not allowing free airflow around the battery charger will limit the device’s capability to transfer the heat energy to the outside world.

In consequence, it will reach its limit internal T_{max} temperature earlier than expected. This will limit the power output capability of the charger.

The charger will start to limit its output power earlier, and at a given temperature, the output rating will be less.

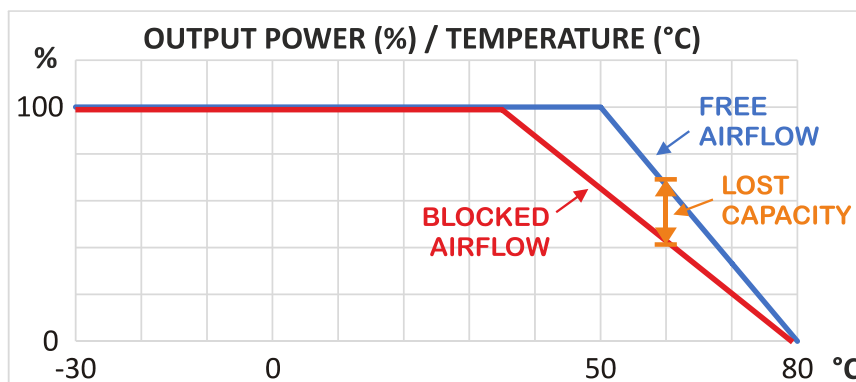

Preventing airflow will reduce the charger rating in high temperature.

11.2. OPERATION AT HIGH AMBIENT TEMPERATURES

The internal temperature of the charger is limited to the T_{max} value of 85°C (185°F). Basically, it will be able to operate up to this limit. A correctly installed charger will deliver its rated output until 50°C at 230VAC (45°C at 115VAC). Above this temperature, the output current will be gradually reduced, finally reaching 0.0 amps at T_{max} .

Above the T_{max} limit the charger will shut down its output and wait. If the temperature falls below T_{max} , it will start to operate again.

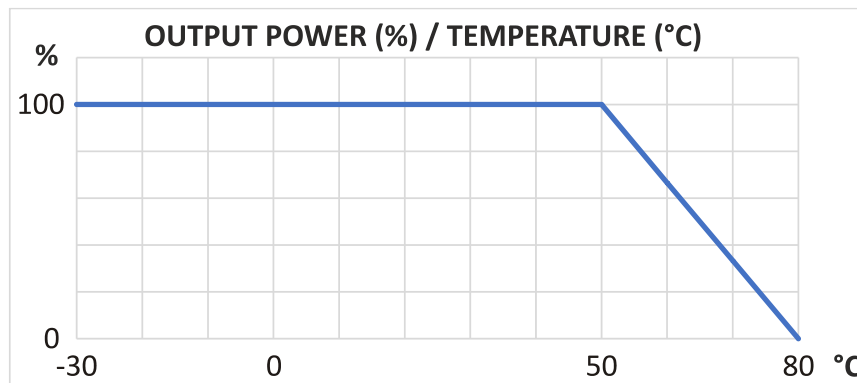

**The destruction limit of the battery charger is 105°C (221°F).
If the ambient temperature goes above this limit, the charger will fall out of service.**

12. POWER DISSIPATION, EFFICIENCY

It should be known that battery chargers are **heat dissipating** devices.

Basically, the charger provides regulated DC power using unregulated AC power. Thus, it is a power conversion device.

The device converts power with a given efficiency. This means that a part of the power supplied from the input, is transformed to useful output energy and another part is simply converted to heat as a result of the charger operation.



Every battery charger heats!

The amount of the dissipated heat energy increases with the output power demand and decreases with the battery charger's efficiency.

Thus, a more efficient charger, compared to an ordinary charger is capable of providing the same output power with less input power. This directly implies that losses are less, and under the same load conditions, the more efficient charger will heat less than the ordinary one.



An efficient battery charger is an environment friendly device, because it consumes less energy to perform the same task.

BC and SBC series are deeply studied devices for a better efficiency. They use the latest developments in electronic components and represent the industry's highest peak in efficiency and environment friendliness.



Please see datasheets of individual chargers for efficiency graphs.

In general, 24V chargers are more efficient than 12V chargers. A charger has a better efficiency at a higher AC input voltage than at a lower input voltage.

EFFICIENCY GRAPH:

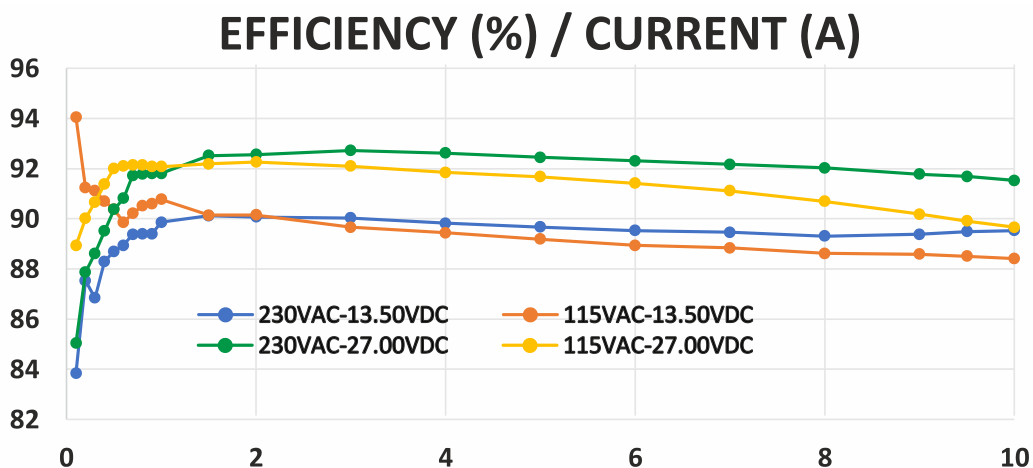

12.1. EFFECT OF SUPPLY VOLTAGE

The efficiency of the battery charger increases with voltage. Thus, operating at low voltages causes more self-heating and may be avoided for the best performance.

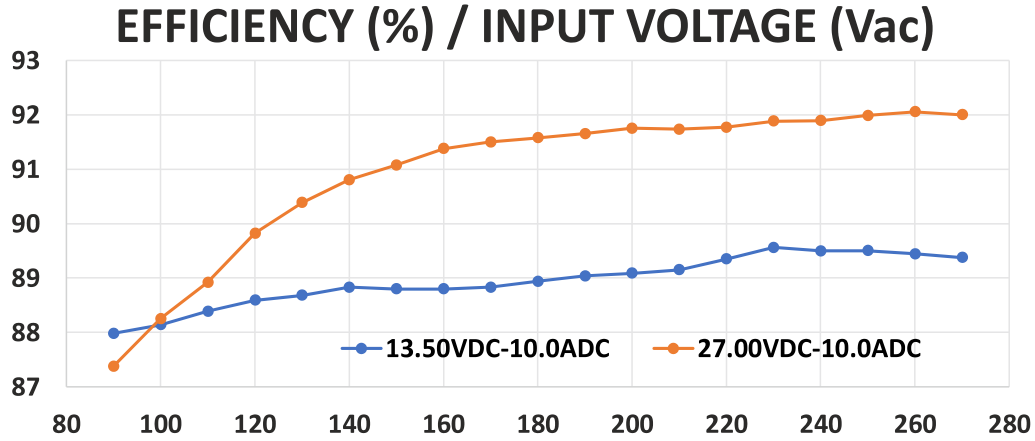

Possible improvements:

- Use the phase with highest voltage to supply the battery charger
- In 100-120V networks consider supplying the battery charger with phase-to-phase voltage.

13. WIRING DIAGRAM

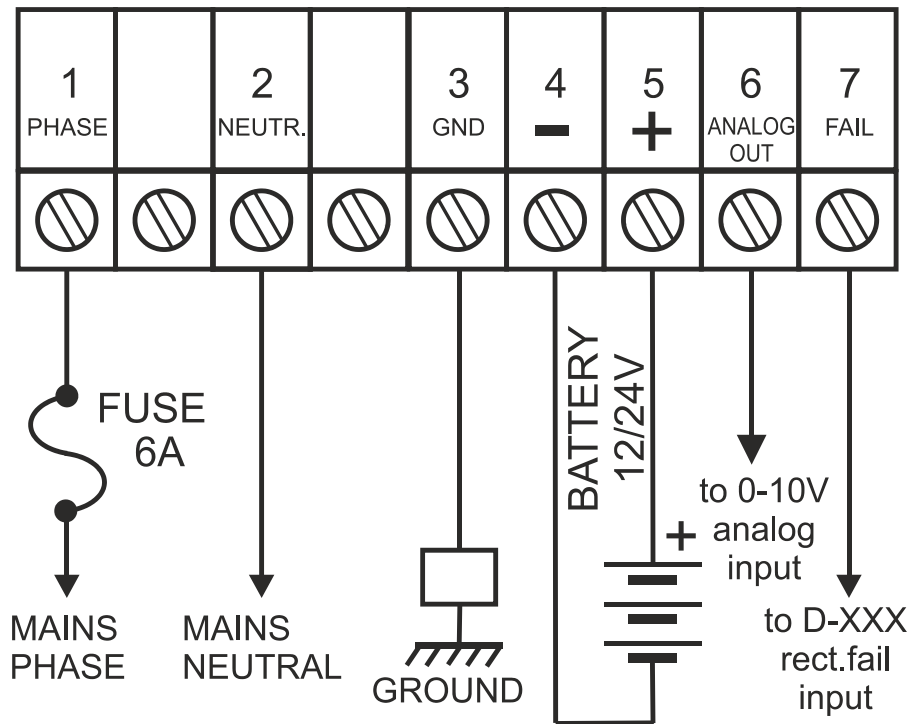

PHASE INPUT: This is the power supply input for the battery charger. Please see technical specifications for ratings. A fast type fuse should be used in series with this input.

NEUTRAL INPUT: Neutral terminal of the supply voltage.

GROUND: Connect this terminal to the earth for electric shock protection.

NEGATIVE OUTPUT: This is the negative terminal of the DC power output. The output is short circuit and overload protected.

POSITIVE OUTPUT: This is the positive terminal of the DC power output. The output is short circuit and overload protected.

ANALOG OUTPUT: This output provides a DC voltage proportional to the charger output current. It can be used to drive a measuring instrument or controller.

CHARGER FAIL OUTPUT: This is a protected semiconductor output pulling to battery negative in case of non-functionality of the output stage. The output is protected against overload and short circuit. A freewheeling diode allowing direct connection to a relay is included inside the device. The failure indication may be caused by a failure, by a blown input fuse or simply by a mains failure. The signal is usually fed to a controller which make the difference between a mains failure and a device fault.

14. TECHNICAL SPECIFICATIONS

Technology: Switchmode, flyback 65 kHz

Output voltage (Vo): autoselect, see DIP switch settings

Output current (Io): 10 ADC max.(continuous)

Input voltage range: 90-300 VAC (110-277V nominal)

Input current: 8.0 ARMS max. (@90VAC)

Input frequency range: 45-68 Hz

Cooling: natural convection

Maximum input power: < 320 Watts

Peak Efficiency: > 92.5% (230VAC, 24VDC)

Output power: 290 Watts max continuous,

No load power: < 0.45W @ 230VAC (< 0.4W @ 115VAC)

Output ripple: < 0.5% of Vo (peak-to-peak)

Output noise: < 40mV RMS

Load regulation: < 0.5% of Vo

Line regulation: < 0.01% of Vo

Warm-up voltage: < 0.5% of Vo

Overshoot: < 3% of Vo (@100% to 0% load change)

Current consumption from battery: < 18mA

Overload protection: limits output current to 10A

Short circuit protection: limits output current to 10A

Short circuit duration: unlimited

High temp. protection: limits internal temp. to 85°C

Rectifier fail output: negative pulling protected semiconductor, rated 1Amp@30VDC

Analog output: 0.5V/A

Isolation:

Input-output: >3300 VAC

Input-ground: >1650 VAC

Output-ground: >1650 VAC

Operating temperature range: -30 °C to +70 °C

Storage temp. range: -40 °C to +80 °C

Max relative humidity: 95% (non condensing)

Dimensions: 106mm(W) x 115mm(H) x 57mm(D)

Weight (approx): 320 grams

Electrical connections: two part connector, 2.5 mm²

15. CURRENT CONSUMPTION FROM BATTERY

The charger supplies its internal circuits through its internal power supply, but, if the AC voltage is not available, then output stage circuits will draw current from the battery.

This current is much smaller than other control devices supplied by the battery.

Please see the technical specifications section for the value of the current consumption.

16. AUTO SELECT OPERATION

The charger selects its output voltage automatically.

If the voltage at output terminals is lower than 18VDC, then the charger is in 12V mode. If the voltage is higher than 18VDC, the charger switches to 24V mode.



If there is no battery connected, then the charger will operate at 12V mode.

The auto-select operation feature helps the user to reduce the number of different items in his stock. The same battery charger will be used in 12V and 24V systems.

17. PARALLEL OPERATION

BC and SBC series battery chargers are able to operate in parallel in order to reach higher output currents and providing redundant operation.

They are also designed to operate in parallel with the charging alternator and do not require any special care during installation.

No special care needs to be taken during paralleling. However, chargers do not feature load sharing. Thus, the load distribution between chargers may not be equal. This is harmless.

All FAIL outputs may be tied in parallel. Thus, any charger activating its FAIL output, will cause the controller to detect it.

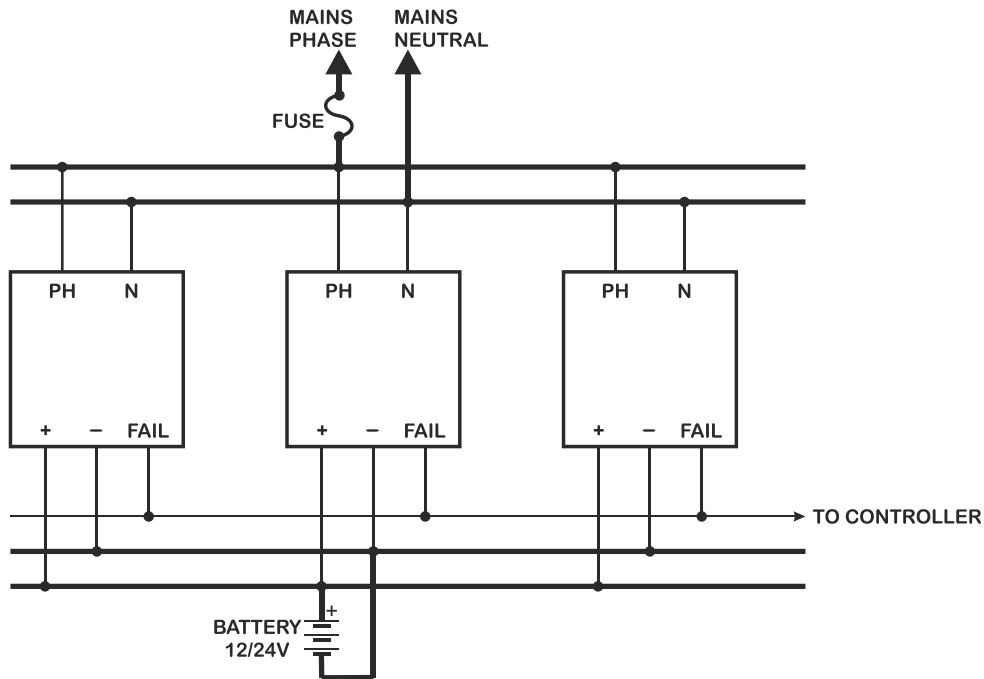

PARALLELING BATTERY CHARGERS

18. SERIES OPERATION



Series operation is not allowed and may cause permanent damage to the charger.

19.CONSTANT VOLTAGE, LIMITED CURRENT OPERATION

Below is the output characteristics of a charger at a given instant.

Output voltage and current values are always at some point on the green/red coloured curve.

If the current demand is less than the rated current (I_o), then the voltage is the nominal voltage.

If a current of more than the rated current (I_o) is demanded, then the charger reacts by reducing its output voltage. But anyway, it does not supply more than I_s , which is typically 105% of I_o .

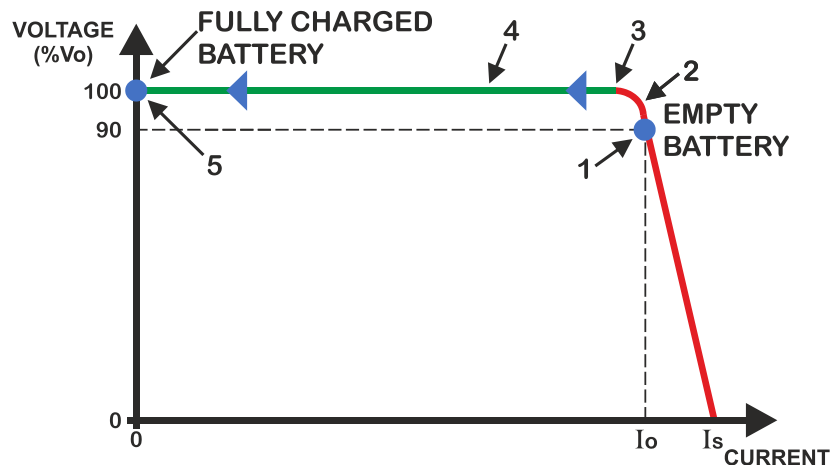

- 1> When we start charging an empty battery with this charger, at first, the voltage is around 90% of the nominal voltage, thus the charger supplies its rated current.
- 2> As long as the battery gets charged, its voltage rises and the operation point travels up and left on the red curve.
- 3> When the voltage V_o is reached, the charger output voltage stops rising.
- 4> The voltage is constant at V_o and the current starts to fall.
- 5> When the current falls to zero, this means that the charge cycle has ended.

Depending on the charging method applied, V_o may be the float charge voltage, absorption voltage, trickle charge voltage or even the boost charge voltage.

V_o will also depend on the battery type and the number of cells inside the battery.

20. TWO STAGE CHARGING

This is a simple and safe charging method allowing to reach a charge level of 90% of the battery capacity, without any risk of damage.

The 2-stage charging provides good battery life, although it does not provide battery maintenance for maximum lifetime.

It does not carry any risk of overcharging or gassing.

It has the advantage of being cost-effective and reasonably performant.

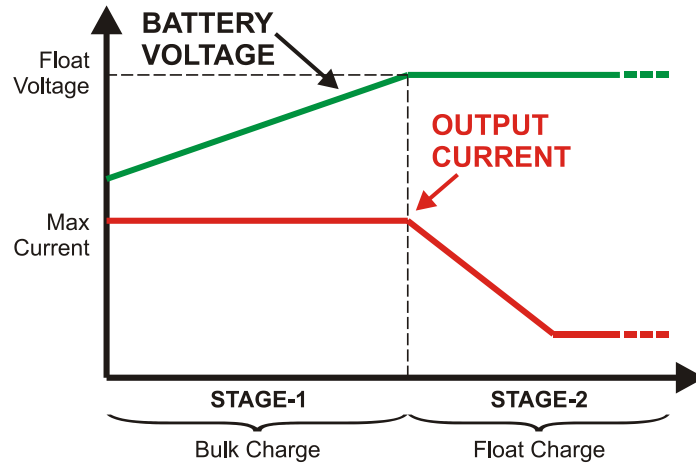

STAGE-1:

If the battery voltage is below the float voltage, referred as V_o , then the unit is in the bulk charge stage and it delivers continuously its maximum output current, referred as I_o .

Thus, the missing charge in the battery will be completed as quickly as possible.

STAGE-2:

When the battery voltage reaches the float level, the unit switches to float charge mode where the output voltage is constant at V_o indefinitely.

21. FOUR STAGE CHARGING, SMART CHARGING

The smart charger has a 4-stage charging system controlled by a microprocessor.

It charges batteries better than traditional 2-stage chargers and provides longer battery life.

The 4-stage charging algorithm is designed to charge the battery at 100% of its capacity and to provide the longest battery life by applying automatic periodic regenerative (trickle) charge cycles.

100% charge level is achieved by maintaining the highest possible charging voltage at battery terminals and resuming to the float charge voltage when the battery is fully charged. This high voltage level allows all cells inside the battery to be fully charged, thus reaching the full capacity.

The regenerative (trickle) charging algorithm extends battery life insuring 100% charge with the lowest float voltage. A lower float voltage insures longer battery life.

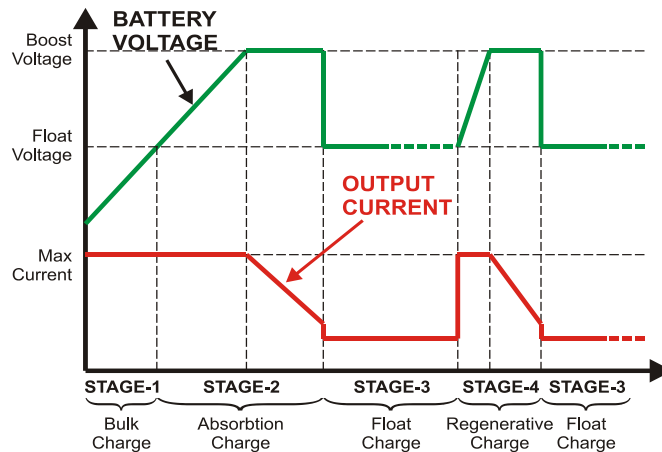

STAGE-1: BULK CHARGE

If the battery voltage is below the float voltage level, then the unit is in the bulk charge stage and it delivers continuously its maximum output current, referred as I_o .

Thus, the missing charge in the battery will be completed as quickly as possible.

STAGE-2: ABSORPTION CHARGE

When the battery voltage reaches the float level, the charger continues charging at its maximum current until the boost voltage is reached. When the boost voltage is reached, the output current starts to drop.

The duration of the absorption charge stage is determined by DIP switch settings. When the set duration is elapsed, the charger will switch to the next stage.

This stage may also be cancelled by DIP switch settings. In this case, this stage will be skipped and the charger will jump from stage-1 to stage-3.

STAGE-3: FLOAT CHARGE

In this stage, the output voltage is constant at V_o .

If the regenerative charge is enabled by DIP switch setting, then periodically the charger will switch to the next stage.

If the regenerative charge is disabled, then it will stay in this mode until a mains failure occurs.

STAGE-4: REGENERATIVE CHARGE

This stage is similar to the stage-2, but it is activated periodically if enabled by DIP switch settings.

The activation period is 6 hours and the duration is 5 minutes.

At the expiration of the stage duration, the charger returns to stage-3 (float charge).



If selected by DIP switches, be sure that the battery accepts absorption charge and regenerative (trickle) charge. Otherwise battery damage may occur.

22. BATTERY TYPE SELECTION

The charger allows the user to select between 4 different battery types.

- Lead-Acid, low voltage
- Lead-Acid, high voltage
- Nickel-Cadmium
- Lithium-Ion

Thus, the same charger is able to charge all types of batteries.

23. DIP SWITCH SETTINGS

The charger features a set of 5 DIP switches allowing to select the battery type, operational timers and operation modes.

Below settings are available:

SW1:

- ON:** activate regenerative charge (5 min every 6 hours)
- OFF:** regenerative charge is disabled

SW2:SW3: absorption charge duration

- ON:ON :** 2 hours
- OFF:ON:** 1 hour
- ON:OFF:** 30 minutes
- OFF:OFF:** absorption charge is disabled

SW4:SW5: Battery type selection

SW4	SW5	BATTERY TYPE	FLOAT VOLTAGE (V)		ABSORPTION VOLTAGE (V)	
			12V	24V	12V	24V
ON	ON	Li-Ion	13.2	26.4	13.7	27.4
OFF	ON	Ni-Cd	14.0	28.0	14.5	29.0
ON	OFF	Ld-Ac	13.8	27.6	14.3	28.6
OFF	OFF	Ld-Ac	13.5	27.0	14.0	28.0



By default, all switches come at OFF position. Thus, the charger is set to charge a lead-acid battery with 2-stage charging algorithm.



Be careful to select the correct battery type, otherwise battery damage may occur.



If selected by DIP switches, be sure that the battery accepts absorption charge and regenerative (trickle) charge. Otherwise battery damage may occur.

24. STATUS INDICATOR

The charger features an ultra-bright green led light indicating its operational status.

This led turns on only when the charger is operating.

If the led light is ON, that shows the AC voltage is present and the charger is operating normally.

If the led is OFF, this shows that the charger is not operating. The reason may be a charger failure, but also a mains failure or a blown fuse will cause the same effect.

Thus, when the led is off, the first action should be to verify that the AC voltage is present at the related charger connector terminals. The voltage should be measured directly on the terminals.

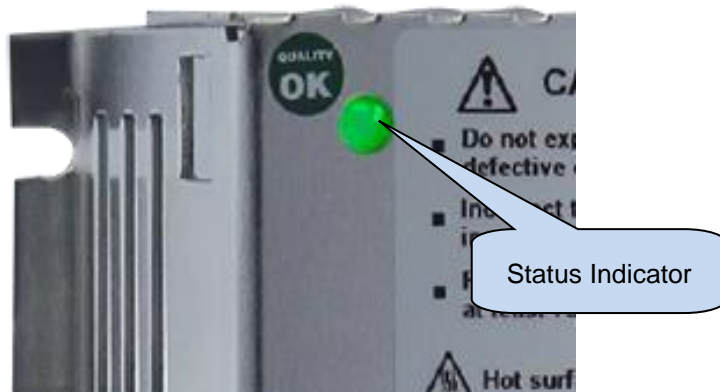

25. FAIL OUTPUT

The charger features a high current capable FAIL output. The output is rated to 1.0 Amp at 30VDC and capable of driving a relay or a digital input.

A free-wheeling diode is included inside the battery charger.

The output will be open contact when the charger is operating and it will pull to battery negative when the charger is not operating. This will cause the external relay to operate (see picture).

If the FAIL output pulls to battery negative, the reason may be a charger failure, but also a mains failure or a blown fuse will cause the same effect.

Thus, when the FAIL output is active, the external logic should check if mains voltage is available. No alarm should be generated when the voltage is not available.

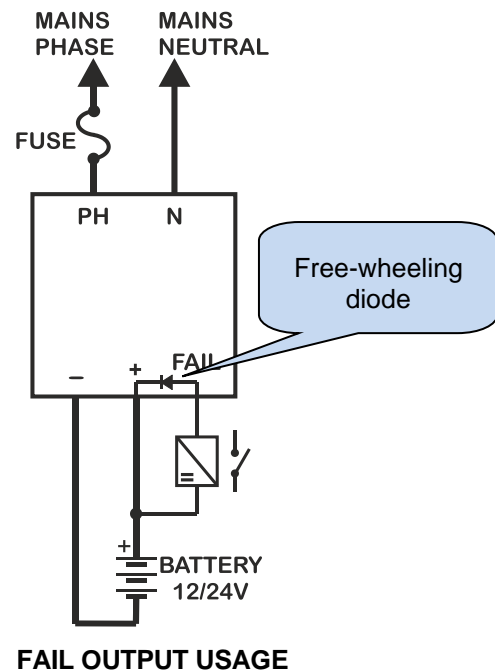

26. ANALOG OUTPUT

The analog output indicates the current flowing out of the charger.

The output signal is 0-5VDC and may be directly interfaced to needle-type displays or PLCs and other measuring instruments.

The sensitivity of the output is: 0.5V/amp
The output impedance is 1000 ohms.

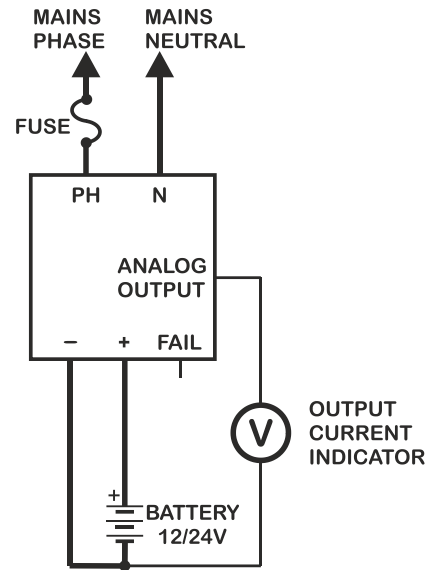

ANALOG OUTPUT USAGE

27. DECLARATION OF CONFORMITY

The unit conforms to the EU directive:
-2014/35/EC (Low Voltage)

Norms of Reference:
-EN 61010 (safety requirements)

The CE mark indicates that this product complies with the European requirements for safety, health, environmental and customer protection.

28. MAINTENANCE



DO NOT OPEN THE UNIT!
There are NO serviceable parts inside the unit.

Wipe the unit, if necessary, with a soft damp cloth. Do not use chemical agents.

29. DISPOSAL OF THE UNIT

Following directive 2002/96/EC of the European Parliament and of the Council of 27 January 2003 on waste electrical and electronic equipment (WEEE), this unit should be stored and disposed separately from usual waste.

30. ROHS COMPLIANCE

The unit is compliant to “**DIRECTIVE 2011/65/EU OF THE EUROPEAN PARLIAMENT AND OF THE COUNCIL of 8 June 2011 on the restriction of the use of certain hazardous substances in electrical and electronic equipment**”.

Any of below substances is not used in this device:

- Lead (Pb)
- Mercury (Hg)
- Cadmium (Cd)
- Hexavalent chromium (Cr6+)
- Polybrominated biphenyls (PBB)
- Polybrominated diphenyl ether (PBDE)
- Bis(2-ethylhexyl) phthalate (DEHP)
- Butyl benzyl phthalate (BBP)

31. TROUBLESHOOTING

The green led is OFF

- a) There is no AC voltage input to the charger.
 - Check the AC voltage at charger connector.
 - Check that the AC voltage and frequency is inside the limits indicated in the brochure.
 - Change the female connector. There may be damaged terminals inside it.
- b) The battery charger fuse is blown
 - Check if there is a blown fuse inside the electrical panel.
- c) The charger is faulty
 - Contact manufacturer's technical support division.

The FAIL output is active

- a) There is no AC voltage input to the charger.
 - Check the AC voltage at charger connector
 - Check that the AC voltage and frequency is inside the limits indicated in the brochure
 - Change the female connector. There may be damaged terminals inside it.
- b) The battery charger fuse is blown
 - Check if there is a blown fuse inside the electrical panel
- c) The charger is faulty
 - Contact the manufacturer's technical support division

The charger becomes hot

- a) The airflow through the charger is obstructed. Consider redesigning the electrical panel and providing more free space around the charger.
- b) This is normal. During battery charging, the charger will provide full power and will be hot in consequence. It will cool down when the battery charge cycle finishes.
- c) If you can touch the charger, it is below 55 degrees C (130 degrees F) which is well below the protection limit. It can be up to 85 degrees C (185 degrees F).

The charger does not provide its nominal output current

- a) The charger is in high-temperature protection mode.
 - The airflow through the charger is obstructed. Consider redesigning the electrical panel and provide more free space around the charger.
 - The ambient temperature is too high.
 - Direct sunlight falls on the electrical panel or genset. Consider a sun-protecting hood over the electrical panel and the genset.

The output voltage is below nominal

- a) The charger is in current limiting mode
 - The battery is getting charged, the voltage will rise at the end of charge.
 - There is a damaged cell inside the battery. Change the battery.
- b) The charger is in high-temperature protection mode.
 - The airflow through the charger is obstructed. Consider redesigning the electrical panel and providing more free space around the charger.
 - The ambient temperature is too high.
 - Direct sunlight falls on the electrical panel or genset. Consider a sun-protecting hood over the electrical panel and the genset.

The output voltage is above nominal

- a) The charger is in 4-stage mode and absorption or regenerative (trickle) charge stage is active:
 - This is normal, the voltage will fall to the float level when the current stage finishes.
- b) The charger is faulty
 - Contact the manufacturer's technical support division

The battery gets hot

- a) Faulty battery type or charging mode is selected.
 - Charging voltage is too high for the battery. Check DIP switch settings.
- b) The battery is getting charged,
 - The battery will cool down at the end of charge
 - The charger output current rating is too high for this battery. Consider changing the charger with a smaller one. The charger rating should be below 10% of the battery capacity.
- c) There is a damaged cell inside the battery.
 - Change the battery.