

DKG-325

GENSET CONTROL & ATS PANEL INSTALLATION GUIDE

DKG-325, is a ready-to-use control and transfer panel for gasoline and diesel gensets rated up to 15kVA. It supports both 1 and 3 phase gensets. The unit incorporates all necessary components for battery charging, genset control and load transfer. It features 2 contactors, battery charging rectifier and the automatic control circuitry in one enclosure.

Internal contactors are rated for 40Amp switching and are capable of carrying 25Amp continuously. Fuel and crank outputs are provided through 40Amp rated relays. The internal battery charging rectifier is rated 1Amp @12V-DC.

The unit features 3 internal current transformers. It measures currents and power from both genset and mains.

SAFETY FIRST !



SAFETY NOTICE
Failure to follow below instructions may result in death or serious injury

- Electrical equipment should be installed only by qualified specialist. No responsibility is assured by the manufacturer or any of its subsidiaries for any consequences resulting from the non-compliance to these instructions.
- Check the unit for cracks and damages due to transportation. Do not install damaged equipment.
- Do not open the unit. There is no serviceable parts inside.
- Fuses of fast type with a maximum rating of 6A for the battery positive and 25A for mains phases must be connected in close proximity of the unit.
- Disconnect all power before working on equipment.
- When the unit is connected to the network do not touch terminals.
- Any electrical parameter applied to the device must be in the range specified in the user manual. Values exceeding limits may shorten device life, destroy its precision or damage it.
- Do not try to clean the device with solvent or the like. Only clean with a damp cloth.
- Do not allow water to come in the unit.
- Verify correct terminal connections before applying power.
- Only for front panel mounting.



WARNING :
Usage of fuses of higher rating than allowed may cause serious hazards.

INSTALLATION

Before installation:

- Read the user manual carefully, determine the correct connection diagram.
- Remove all detachable connectors and mounting brackets from the unit, then pass the unit through the mounting opening.
- Put mounting brackets and tighten. Do not tighten too much, this can brake the enclosure.
- Make electrical connections with plugs removed from sockets, then place plugs to their sockets.
- Make sure that the ambient temperature does not exceed the maximum operating temperature limit.



Make electrical connections with plugs removed from sockets, otherwise the unit may get damaged.

During Installation:

- Cables should be compatible with the operating temperature range. Use adequate cable section, at least 0.75mm² (AWG18).

Below conditions may damage the device:

- Incorrect connections.
- Incorrect battery voltage.
- Reverse battery voltage
- Voltage at terminals beyond specified range.
- Voltage applied to digital inputs over specified range.
- Overload or short circuit at relay outputs.
- Excessive vibration, installation on vibrating parts.

Below conditions may cause abnormal operation:

- Battery voltage below minimum acceptable level.
- Frequency out of specified limits
- Missing grounding.



Do not install the unit close to high electromagnetic noise emitting devices like contactors, high current busbars, switchmode power supplies and the like.



Engine body must be grounded for the correct operation of the unit. Otherwise faulty voltage and frequency measurements may occur.

INSTALLATION DIAGRAM

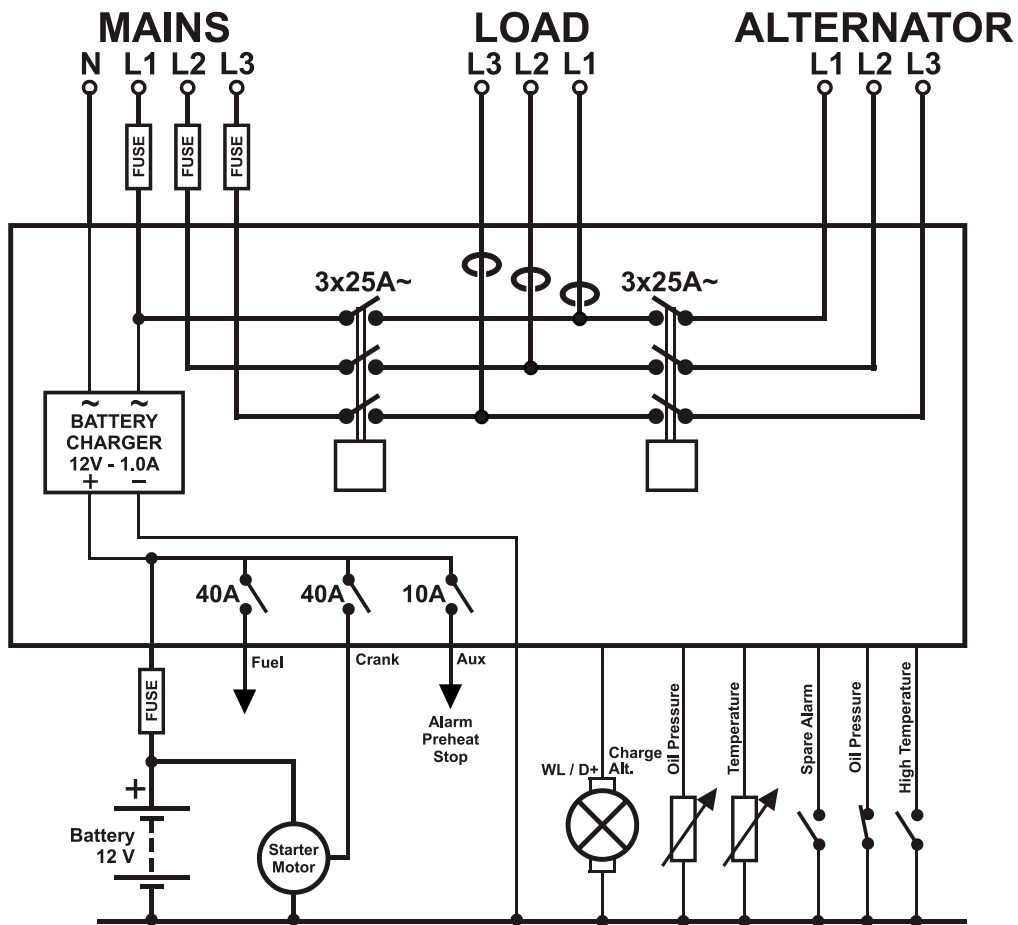

Battery negative must be grounded.

TECHNICAL SPECIFICATIONS

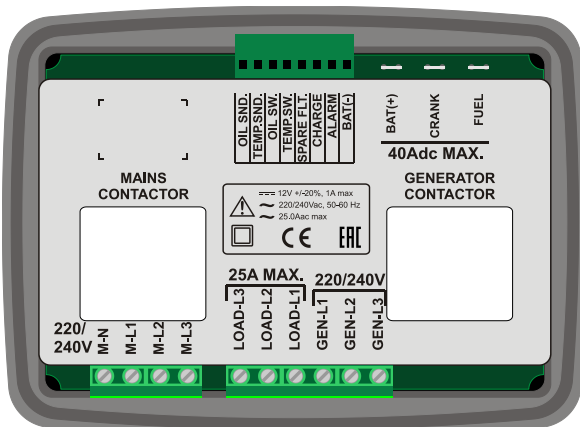

DC Supply Range: 9.0 - 16.0 V-DC.

DC supply current:

250 mA-DC typical @12V-DC

500 mA-DC max. @12V-DC

Alternator Voltage: 0-280 V-AC (Phase-Neutral)

Alternator Frequency: 0-100 Hz.

Mains Voltage: 0-280 V-AC (Phase-Neutral)

Mains Frequency: 0-100 Hz.

Load Current: 3x25A / 230V-AC continuous

Cranking Dropouts: survives 0V for 100ms.

Fuel and Crank Relay Outputs: 40 A / 12V-DC

Alarm Output: 10A / 12 V-DC

Charge Excitation: min 2 W.

Battery Charge Current: min 1A / 13.7V-DC (195-276V-AC)

Operating temp.: -40°C (-40°F) to 70°C (158°F).

Storage temp.: -55°C (-67°F) to 80°C (176°F).

Maximum humidity: 95% non-condensing.

Dimensions: 200x 148 x 72 mm (GxYxD)

Panel Cutout: 176 x 121mm minimum.

Weight: 700 g (approx.)

Enclosure: Flame retardant, high temp ABS/PC (UL94-V0)

IP Protection: IP54 (front).

EU Directives

-2006/95/EC (low voltage)

-2004/108/EC (electromagnetic compatibility)

Reference standards for EU Conformity:

-EN 61010 (safety)

-EN 61326 (EMC)

PUSHBUTTON FUNCTIONS

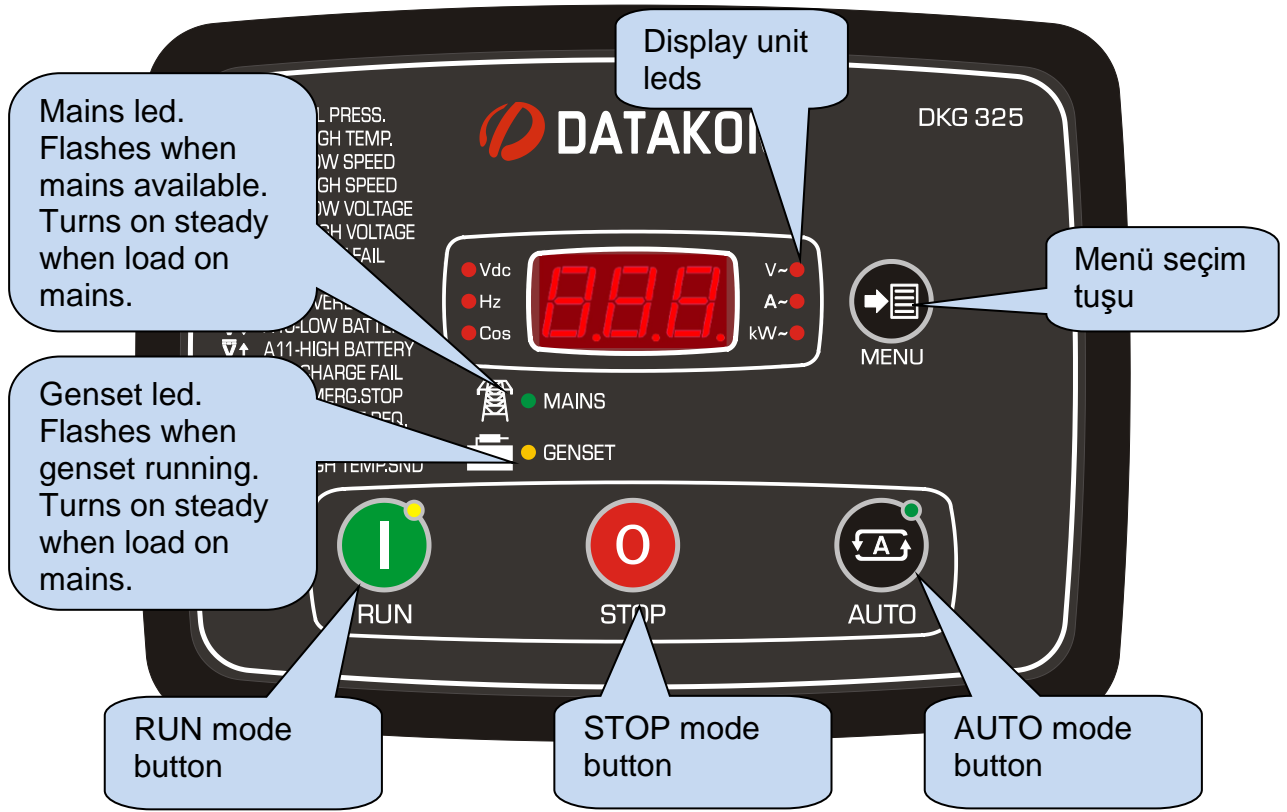

BUTTON	FUNCTION
	Genset runs off load.
	If the mains fail, then the genset runs and takes the load.
	Genset stops. If held pressed during 10 seconds, resets service counters.
	Selects next display value. If held pressed then selects first LAMP TEST the programming mode.
	If these two buttons are held pressed for 5 seconds, enters the special programming mode where high priority parameters are also programmable.

MODE LEDS: Turns on when related mode is selected on the unit.

STOP: In this mode, if mains phase voltages are within the programmed limits then the mains contactor will be energized. The engine does not run.

AUTO: If at least one of the mains phase voltages is outside limits, the mains contactor will be deactivated. The engine will run. When alternator phase voltages and frequency are within limits, then the generator contactor will be energized.

When all the mains phase voltages are within the limits, the generator contactor is deactivated and the mains contactor will be energized and the diesel will stop. The unit will be ready for the next mains failure.

RUN: The operation of the generator is similar to the AUTO mode, but the mains contactor will not be deactivated and the genset will run off load.

MAINS AND GENSET LEDS:

MAINS: If mains phase voltages and frequency is within limits then this led flashes. When the load is on mains, this led turns on steady.

GENSET: If genset phase voltages and frequency is within limits then this led flashes. When the load is on genset, this led turns on steady.

PROGRAMMING

Programming mode is used to adjust delays, operating limits and configuration of the unit.

In order to enter the program mode please hold pressed the MENU button for 10 seconds.

In program mode, when the MENU pushbutton is depressed, the display shows the program number. When MENU pushbutton is released the program parameter value is displayed.

Entering the program mode does not affect genset operation. If mains fail during programming, then the genset will automatically run and take the load.

Program parameters may be scrolled with MENU button. If the pushbutton is held pressed then the parameter number increases faster.

Parameter value is increased/decreased with RUN (▼) and AUTO(▲) pushbuttons. If the pushbutton is held pressed then the parameter value increases/decreases faster.

When the program parameter is modified, it is automatically saved in a non-volatile memory.

In order to exit program mode, press the STOP button. If no button is pressed during 1 minute, the unit will automatically exit the program mode.

Program parameters are divided in two groups being low and high priority parameters. If the program mode is entered by pressing the MENU button, only low priority parameters are displayed. In order to display high priority parameters, enter the program mode by holding pressed both MENU and STOP buttons.

PGM	Parameter Name	Unit	Std.	Description
P_01	Fuel output type	-	0	0: activate to start 1: activate to stop
P_02	Oil switch type	-	0	0: oil pressure switch 1: oil level switch
P_03	Single phase operation	-	0	0: tri phased 1: single phased
P_04	Overcurrent limit	A	0	If the current goes above this limit, during the period defined in Overload Timeout then a Overcurrent Load Dump alarm will be generated. If this parameter is 0 then Overcurrent check is disabled.
P_05	Excess power limit	kW	0	If the active power goes above this limit, during the period defined in Overload Timeout then an Excess Power Load Dump alarm will be generated. If this parameter is 0 then Excess Power check is disabled.
P_06	Overcurrent/ Excess Power / Frequency / Voltage delay timer	sec	5	This is the period between OVERCURRENT or EXCESS POWER or VOLTAGE or FREQUENCY limits are exceeded and the related alarm occurs.
P_07	Preheat timer	Sec	1	This is the time after the fuel solenoid is energized and before the genset is started. During this period the PREHEAT relay function is active.
P_08	Choke timer	Sec	5	This is the control delay of CHOKE output. The choke output is activated together with the crank output. It is released after this delay or when engine runs, whichever occurs first.
P_09	Engine heating timer	Sec	4	This is the period used for engine heating before genset takes the load.
P_10	Stop timer	Sec	10	This is the maximum time duration for the engine to stop. During this period the STOP relay function is active. If the genset has not stopped after this period, a FAIL TO STOP warning occurs.
P_11	Mains waiting timer	Min	0.5	This is the time between the mains voltages entered within the limits and the generator contactor is deactivated.
P_12	Cooldown timer	min	1.0	This is the period that the generator runs for cooling purpose after the load is transferred to mains.
P_13	Mains voltage low limit	V	170	If one of the mains phases goes under this limit, it means that the mains are off and it starts the transfer to the genset in AUTO mode.
P_14	Mains voltage high limit	V	270	If one of the mains phases goes over this limit, it means that the mains are off and it starts the transfer to the genset in AUTO mode.



Following parameters are in the “high priority” group.