

## DESCRIPTION

DATAKOM SMPS series are fixed output voltage, current limited lead acid and Nickel-Cadmium battery chargers specially designed for permanent connection to genset starter batteries.

They maintain the batteries fully charged, without overcharging or gassing. Thanks to their continuous DC outputs they may also be used in a wide range of industrial applications where DC power is required.

When the battery voltage is below the float charge level, the charger provides constant current, nearly equal to the rated output current allowing a rapid recovery of the missing charge. When the battery voltage reaches the float level, the charger switches to constant voltage charge mode and maintains the battery fully charged, providing the maximum battery life.

The chargers are designed in switchmode technology. Their rugged design allows surviving in harsh electromagnetic environments found in automotive industry.

The unit has overload and short circuit protections. This feature makes the units deliver only the rated current during engine cranking or a short circuit condition. They do not need disconnection during cranking.

The high temperature protection of the unit reduces the output current in case of overheating.

The low weight of the unit makes it ideal for use in highly vibrating generator control panels. The small dimensions allow compact panel design.

Thanks to their high efficiency, the self-heating of the chargers is kept in minimum levels allowing operation in warm environments.

The chargers are able to operate in parallel with the engine's charge alternator and other battery chargers. Multiple units may be connected in parallel in order to obtain higher current ratings.

The wide input voltage range allows the chargers to be used in most countries.

The rectifier fail output is provided as a standard feature. This is a semiconductor output pulling to battery negative when the unit is not operating. Thanks to this output, a rectifier fail signal is provided for the genset control module which will give an alarm in case of failure.



The units provide a “boost charge” input as a standard feature. When this input is pulled to battery negative, the output voltage of the charger will be set to the boost charge voltage. This feature may be used temporarily to improve battery life.

The chargers have open chassis, metal cased design, suitable for bolt and stud mounting in an enclosed panel.

## FEATURES

- 100 KHz switchmode architecture**
- Float charging system**
- Constant voltage output**
- Current limited**
- Rugged design for industrial environments**
- Wide operating voltage range**
- Rectifier fail output**
- Boost charge input**
- Short circuit protection**
- Overload protection**
- High temperature protection**
- Analog output for charge current:  
0-10 Volt-DC (0-10 A)**

## INSTALLATION



The unit is designed only for installation within other equipment by professional installers. It must not be operated as a stand alone product.

The unit is for enclosed panel mounting. The user should not be able to access the unit. Only authorized service personnel will be allowed to access the unit. Mount the unit on a flat, vertical surface. Allow at least 5cm space on the bottom and top sides to enable cooling by natural ventilation. Blocking the aeration will cause the unit to overheat.



Use 6 Amps external fuse at the phase input.  
**ALWAYS disconnect the power BEFORE connecting the unit.**

## MAINTENANCE



**DO NOT OPEN THE UNIT.**  
There are **NO** serviceable parts inside The unit.

Wipe the unit, if necessary with a soft damp cloth. Do not use chemical agents.

## TECHNICAL SPECIFICATIONS

		1210	2410
Technology	-	Switchmode (forward) 100KHz	
Output Voltage	V-DC	13.7	27.4
Output Current	Amp.	10	10
Input Voltage Range	V-AC	170-300	
Input Frequency Range	Hz	45-65	
Operating Temp. Range	°C	-20 / +70	
Storage Temp. Range	°C	-40 / +80	
Max. Relative Humidity (non-condensing)	%	95	
Max. Input Power	Watt	170	320
Efficiency (at full load)	%	85	88
Output Noise (Vpp)	Volt	0.4	
Load Regulation	Volt	0.2	
Line Regulation	Volt	0.2	
Output Voltage Overshoot	%	3	
Output Voltage Rise Time	ms	50	
Input Inrush Current (for 10 ms)	Amp.	30	50
Rectifier Fail Output Impedance	ohm	270	
Boost Charge Voltage	Volt	15.0	30.0
High Temp. Protection	-	Yes	
Short Circuit Protection	-	Yes	
Width	mm	90	
Height	mm	175	
Depth	mm	82	
Weight (approx.)	gram	600	610
Electrical Connections	2 Part plug-in connectors, Screw terminals and Fast-on connector		

## CONNECTION DIAGRAM

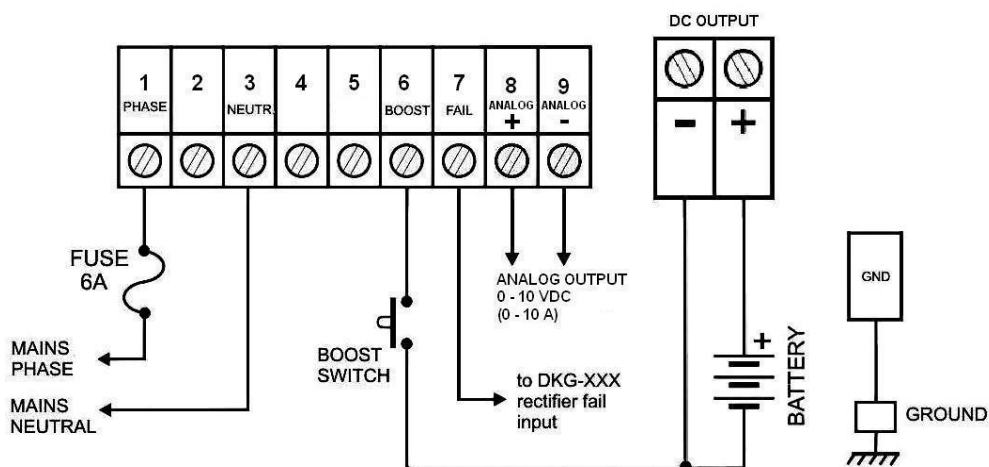

**DATAKOM Electronics Ltd.**

Tel: +90-216-466 84 60

Fax: +90-216-364 65 65

e-mail: [datakom@datakom.com.tr](mailto:datakom@datakom.com.tr)

<http://www.datakom.com.tr>