

DKG-205

**AUTOMATIC
MAINS FAILURE UNIT**

TABLE OF CONTENTS

Section

- 1. PROGRAMMING SUMMARY**
- 2. INSTALLATION**
 - 2.1. Introduction to the Control Panel**
 - 2.2. Mounting the Unit**
 - 2.3. Wiring the Unit**
 - 2.4. Inputs and Outputs**
 - 2.5. Digital display**
 - 2.6. Led displays**
 - 2.7. Periodic maintenance request display**
 - 2.8. Alarms**
 - 2.9. Modes of Operation**
- 3. MAINTENANCE**
- 4. TROUBLESHOOTING**
- 5. PROGRAMMING**
- 6. CALIBRATION**
- 7. TECHNICAL SPECIFICATIONS**
- 8. DECLARATION OF CONFORMITY**
- 9. CONNECTION DIAGRAM**

1. PROGRAMMING SUMMARY

To enter the program mode, press the PGM button. The display shows (Pr) when program mode is selected.

PGM NUMBER	PROGRAM OPTION	UNIT	FACT SET	MIN. VAL.	MAX. VAL.
P01	Mains Voltage Lower Limit	Volt	170	30	250
P02	Mains Voltage Upper Limit	Volt	270	100	400
P03	Generator Voltage Lower Limit	Volt	180	30	250
P04	Generator Voltage Upper Limit	Volt	270	100	400
P05	Frequency Lower Limit	Hz.	45	10	60
P06	Frequency Upper Limit	Hz.	57	50	100
P07	Frequency Delay Timer	Sec.	3	0	15
P08	DC Supply Upper Limit	Volts	33.0	12.0	33.0
P09	Number of Start Attempts	-	3	1	6
P10	Wait before Start Timer	Sec.	3	0	240
P11	Wait between Starts Timer	Sec.	10	1	30
P12	Start Timer	Sec.	10	2	15
P13	Stop Timer	Sec.	0	0	60
P14	Mains Waiting Timer	Min.	0.5	0	15
P15	Cooling Timer	Min.	1.0	0	15
P16	Mains Contactor Timer	Sec.	1	0	15
P17	Generator Contactor Timer	Sec.	4	0	15
P18	Relay Configuration	-	0	0	7
P19	Maintenance Period (engine hours)	hours	0	0	750
P20	Maintenance Period (duration)	months	0	0	15

2. INSTALLATION

2.1 Introduction to the Control Panel

The control panel is designed to provide user friendliness for both the installer and the user. Programming is usually unnecessary, as the factory settings have been carefully selected to fit most applications. However programmable parameters allow the complete control over the generating set. Programmed parameters are stored in a Non Volatile Memory and thus all information is retained even in the event of complete loss of power.

2.2 Mounting the Unit

The unit is designed for panel mounting. The user should not be able to access parts of the unit other than the front panel.

Mount the unit on a flat, vertical surface. The unit fits into a standard panel meter opening of 140x68 millimeters. Before mounting, remove the steel spring from the unit, and then pass the unit through the mounting opening. The unit will be maintained in its position by the steel spring.

2.3 Wiring the Unit

WARNING: THE UNIT IS NOT FUSED.

Use external fuses for

Mains phases: R-S-T

Generator phase: L1-L2-L3

Battery positive: BAT(+).

Install the fuses as nearly as possible to the unit in a place easily accessible for the user.

The fuse rating should be 6 Amps.

**WARNING: ELECTRICITY CAN KILL
ALWAYS disconnect the power BEFORE
connecting the unit.**



- 1) ALWAYS remove the plug connectors when inserting wires with a screwdriver.
- 2) ALWAYS refer to the National Wiring Regulations when conducting installation.
- 3) An appropriate and readily accessible set of disconnection devices (e.g. automatic fuses) MUST be provided as part of the installation.
- 4) The disconnection device must NOT be fitted in a flexible cord.
- 5) The building mains supply MUST incorporate appropriate short-circuit backup protection (e.g. a fuse or circuit breaker) of High Breaking Capacity (HBC, at least 1500A).
- 6) Use cables of adequate current carrying capacity (at least 0.75mm^2) and temperature range.

2.4 Inputs and Outputs

SERIAL DATA CONNECTION: This connection is used to transfer data to the PC via the serial adapter.

1- GENERATOR CONTACTOR: This output provides energy to the generator contactor. If the generator phase voltage is outside of the programmed limits, the generator contactor will be de-energized. In order to provide extra security, normally closed contact of the mains contactor should be serially connected to this output. Relay contact rating is 16A/250V-AC

2/3/4- L1/L2/L3: Connect the generator phases to these inputs. The generator phase voltage upper and lower limits are programmable.

5- GENERATOR NEUTRAL: Neutral terminal for the generator phases.

6- MAINS NEUTRAL: Neutral terminal for the mains phases.

7/8/9- T-S-R: Connect the mains phases to these inputs. The mains voltages upper and lower limits are programmable.

10- MAINS CONTACTOR: This output provides energy to the mains contactor. If the voltage of at least one of the mains voltages is outside of the programmed limits, the mains contactor will be de-energized. In order to provide extra security, normally closed contact of the generator contactor should be serially connected to this output. Relay contact rating is 16A/250V-AC

11- AUXILIARY RELAY OUTPUT: This relay fulfills 4 different functions following programming. Relay contact rating is 10A/28V-DC.

1) **ALARM RELAY:** If an alarm occurs, the relay will be activated. It will be deactivated when the ALARM MUTE key is pressed.

2) **STOP RELAY:** The relay will operate during programmed period in order to stop the engine (Activate to Stop)

3) **PREHEAT RELAY:** The relay will operate the programmed delay before the cranking of the engine. It will be deactivated during cranking and reactivated during the rest period between cranks. It will be deactivated when the engine runs.

4) **CHOKE RELAY:** The relay will operate the programmed delay before the cranking of the engine. It will be deactivated when the engine runs.

12- CRANK OUTPUT: Engine crank output. Relay automatically turns off when the alternator voltage reaches 100 volts or the alternator frequency reaches 10Hz.

Relay contact rating is 10A/28V-DC.

13- FUEL OUTPUT: This output is used on engines equipped with a fuel solenoid. The unit activates this output before starting the engine and deactivates it to stop it. By programming, this relay can also control '**Activate to Stop**' type of engines.

Relay contact rating is 10A/28V-DC.

14- CHARGE INPUT: Connect the charging alternator's lamp output to this terminal. If the charging alternator fails when the engine is running, the related alarm indicator will turn on and the alarm output will be activated. This alarm will not prevent the normal operation of the generating set.

15/16- BAT(+)/BAT(-): The positive (+) and negative (-) terminals of the DC Supply shall be connected to these terminals. Be careful for the polarization, in case of polarity error the unit will not operate. The unit operates on both 12V and 24V battery systems.

17- PROGRAM LOCK INPUT: This input is used to prevent unwanted modification to programmed values. If this input is left open, program values can be modified via the front panel buttons, but if this input is connected to DC Supply (-) it will not possible to change the program values.

18- LOW COOLANT LEVEL SWITCH: Connect the cooling radiator liquid level switch to this input. This switch shall be negative closing in case of low liquid level. This input has delayed sampling feature to prevent false detection.

19- SPARE-3 ALARM INPUT: Connect the spare alarm switch to this input. The switch shall be negative closing type.

20- SPARE-2 ALARM INPUT: Connect the spare alarm switch to this input. The switch shall be negative closing type.

21- SPARE-1 ALARM INPUT: Connect the spare alarm switch to this input. The switch shall be negative closing type.

22- HIGH TEMPERATURE SWITCH: Connect the high temperature switch to this input. This switch shall be negative closing switch type.

23- LOW OIL PRESSURE SWITCH: Connect the low oil pressure switch to this input. The switch should be negative closing in case of loss of oil

pressure. This input must be properly connected for the correct operation of the unit. If oil pressure is provided, the generator will not start and the oil pressure alarm indicator will flash. However, if the oil pressure is removed, the unit will resume normal operation.

24- EMERGENCY STOP INPUT: Emergency stop button is connected to this input. The connection shall be made in order to give DC Supply (-) to the input when the button is pushed. Pushing the STOP button on the unit's front panel makes the same effect as the EMERGENCY STOP input. The generator will not operate when the emergency stop signal is present. When the signal is removed, the unit will resume normal operation. This input can also be used to prevent externally the automatic operation of the generator. (for ex. by time watch).

25- OVERLOAD SWITCH: Connect the overload relay output to this input. The relay will be of negative closing type in case of overload. This alarm will cause the generator to release the load, but the engine runs until the end of the cooling period.

26- ALTERNATOR HIGH TEMPERATURE SWITCH: Connect the high temperature switch placed between windings of the alternator to this input.

WARNING: This switch shall be normally closed, and open in case of excess of heat. If this input is not used, connect it to DC Supply negative terminal, else an alarm will be given continuously. This alarm will cause the generator to release the load, but the engine runs until the end of the cooling period.

27- OIL HIGH TEMPERATURE SWITCH: Connect the oil high temperature switch to this input. This switch shall be negative closing switch type.

2.5 Digital Display

This display shows:

- (R) phase voltage, when mains are on
- Alternator frequency, if the generator is on
- Program values in program mode

Below values can be read in sequence by pushing the MENU key in AUTO or TEST modes:

- (R) phase voltage
- (S) phase voltage
- (T) phase voltage
- (L1) generator phase voltage
- (L2) generator phase voltage
- (L3) generator phase voltage
- (L1) generator phase frequency (engine RPM)
- DC Supply voltage.

2.6 Led Displays

MAINS ON: (green) The LED will turn on when all 3 mains phase voltages are within the limits.

MAINS OFF: (red) The LED will turn on when at least one of the mains phase voltages are outside limits.

GENERATOR: (yellow) The LED will turn on when all 3 generator phase voltages are within the programmed limits.

LOAD GENERATOR: (yellow) it turns on when the generator contactor is activated.

LOAD MAINS: (green) it turns on when the mains contactor is activated.

FUEL: (yellow) it turns on when the (activate before start) fuel solenoid is activated. This LED is operative even if the fuel output is in 'activate to stop' mode.

START: (yellow) it turns on when the start relay is activated.

WAITING/COOLING: (yellow) it turns on during wait periods before and between start attempts, mains waiting period, cooling period and contactor period.

PERIODIC MAINTENANCE REQUEST: (red) It flashes when the programmed maintenance period or the programmed engine-hours is elapsed.

TEST/AUTO/OFF/PGM/MAN: It turns on when the related operation mode is selected. One of these LEDs is always on and indicates which operation mode is selected.

2.7 Periodic Maintenance Request Display

This led is designed to help the periodic maintenance of the generator to be made consistently.

The periodic maintenance is basically carried out after a given engine hours (for example 200 hours), but even if this amount of engine hours is not fulfilled, it is performed after a given time limit (for example 12 months).

The DKG-205 has both programmable engine hours and maintenance time limit. The engine hours is programmable between 0 and 750 hours at 50-hour steps, the time limit is programmable between 0 and 15 months. If any of the programmed value is zero, this means that the parameter will not be used. For example P19=200 and P20=0 means that DKG-205 will request maintenance every 200 engine hours, but there will be no time limit.

The remaining engine hours and the remaining time limit are kept stored in a non-volatile memory and are not modified by power supply failures.

When the engine hours or the time limit is over, the Periodic Maintenance Request led (red) will start to flash. To turn off the led, the STOP key should be held pressed for 10 seconds. In this case the digital display will show 'SER'.

2.8 Alarms

Alarms indicate an abnormal situation in the generating set and most of them cause the engine to stop immediately.

If an alarm occurs, the related LED will turn on and if the alarm relay option is selected, the alarm relay will be activated. If the ALARM MUTE key is pressed, the alarm relay will be deactivated.

Except the emergency stop, alarm LEDs will stay on and disable the operation of the generating set even if the alarm source is removed. In order to reset the alarm condition, first choose OFF mode then resume to the previous mode of operation.

CHARGE ALARM: It turns on in case of a charging alternator failure. This alarm will not cause the engine to stop.

OVERLOAD ALARM: It turns on if a signal comes from the overload relay output. This alarm will cause the generator to release the load, but the engine runs until the end of the cooling period.

ALTERNATOR HIGH TEMPERATURE ALARM: It turns on if a signal comes from the high temperature switch of the alternator. **WARNING:** This switch shall be normally closed, and open in case of excess of heat. If this input is not used, connect it to DC Supply negative terminal, else an alarm will be given continuously. This alarm will cause the generator to release the load, but the engine runs until the end of the cooling period.

HIGH TEMPERATURE ALARM: It is on when a signal comes from the high temperature input.

OIL ALARM: It is on when a signal comes from the oil pressure input. This alarm will be controlled 4 seconds after the engine is running. If oil pressure is provided when the unit attempts to start the engine, the oil alarm indicator will flash and the unit will wait until oil pressure disappears.

LOW COOLANT LEVEL ALARM: It is on when a signal comes from the cooling radiator water level switch. This input has delayed sampling feature to prevent false detection.

OIL HIGH TEMPERATURE ALARM: It is on when a signal comes from the oil high temperature switch.

FREQUENCY ALARM: It is on when the alternator frequency is out of the programmed limits for a longer period than the programmed timer. Alternator frequency will be controlled 4 seconds after the generator contactor is on.

VOLTAGE ALARM: It is on when at least one of the alternator phase voltages is out of the programmed limits. Alternator voltage will be controlled 4 seconds after the generator contactor is on.

FAIL TO START: It is on if the engine cannot start to run after the programmed number of start attempts. This alarm will be erased when the mains are on in order to keep the engine ready for the next mains failure.

EMERGENCY STOP ALARM: It arises if emergency stop button (or front panel STOP key) has been pushed. This alarm is not latched. The alarm condition disappears when the signal is removed. This input is also used externally to prevent the operation of the generator (for ex. by a timer).

DC SUPPLY ALARM: It is on when DC Supply voltage is above the programmed limit. It arises at the end of 2 seconds delay period. It does not occur if DC Supply voltage goes back below the limit before the end of the delay period. This protection is particularly designed against charge alternator failures.

SPARE-1 ALARM: It turns on when a signal comes from the spare-1 alarm input.

SPARE-2 ALARM: It turns on when a signal comes from the spare-2 alarm input

SPARE-3 ALARM: It turns on when a signal comes from the spare-3 alarm input. This alarm will not stop the engine.

2.9 Modes of Operation

The modes of operation are selected by pushing the front panel keys. If the mode is changed while the engine is running, it will be stopped. Do not change the operation mode while the generator is in operation.

OFF: In this mode, the mains contactor will be energized if mains phase voltages are within the programmed limits. The engine will be stopped.

MANUAL: It is used to start and stop the generator manually. If the manual mode is selected, the fuel relay will be activated and the generator will be ready to be started.

START: It is used to manually start the generator unlimited times. In order to start, it is needed not to have the oil pressure. When the generator phase voltages are present or the generator frequency goes over 10 Hz, starting will be automatically disabled even if the button is pressed.

STOP: It is used to manually deactivate the fuel solenoid as long as desired. When the stop button is pushed, the generator contactor will also be deactivated.

MAINS/GENERATOR: It is used to manually activate the mains and the generator contactor. If it is pressed once, the generator contactor will be activated, if it is pressed once the mains contactor will be activated.

AUTO: It is used for generator and mains automatic transfer. If at least one of the mains phase voltages is outside limits, the mains contactor will be deactivated.

The diesel will be started for programmed times after the wait period. When the engine runs, the crank relay will be immediately deactivated. After the alternator phase voltages are within limits, the unit will wait for the generator contactor period and the generator contactor will be energized.

When all the mains phase voltages are within the limits, the engine will continue to run for the mains waiting period. At the end of this period the generator contactor is deactivated and the mains contactor will be energized. If a cooling period is given, the generator will continue to run during cooling period. At the end of the period, the fuel solenoid will be de-energized and the diesel will stop. The unit will be ready for the next mains failure.

TEST: It is used to test the generator when the mains are on, or keep the generator waiting in the emergency backup mode. The operation of the generator is similar to the AUTO mode, but the mains contactor will not be deactivated if the mains are not off. If the mains are off, mains contactor will be deactivated and the generator contactor will be activated. When the mains are on again, a changeover to the mains will be made, but the engine is kept running. In order to stop the engine, push the OFF button.

PROGRAM: It is used to program the timers, operational limits and the configuration.

3. MAINTENANCE

WARNING: DO NOT OPEN THE UNIT

There are NO serviceable parts inside the unit.

Wipe the unit, if necessary with a soft damp cloth. Do not use chemical agents.

4. TROUBLESHOOTING

The genset starts to operate while AC mains are OK:

AC mains voltages may be outside programmed limits. Read AC voltages by pressing the MENU button. Upper and lower limits of the mains voltages may be too tight. Get in the PROGRAM mode and check for the AC voltage upper and lower limits. If necessary, widen the limits.

The genset continues to operate after AC mains are reestablished:

Widen the AC voltage limits. The hysteresis value for the AC voltages is 10 volts. When the AC mains fail, the lower limit is raised and the upper limit is reduced by the hysteresis value to prevent a new load transfer after the load is transferred to the mains.

AC voltages displayed on the unit are not correct:

The error margin of the unit is +/- 5 volts.

If there are faulty measurements only when the engine is running, there may be a faulty charging alternator or voltage regulator on the engine. Disconnect the charging alternator connection and check if the error is removed.

When the AC mains fails the unit energizes the fuel solenoid, but does not start, also OIL PRESSURE ALARM led flashes:

The unit is not supplied with battery (-) voltage at the oil pressure input.

-Oil pressure switch not connected.

-Oil pressure switch connection wire cut.

-Oil pressure switch faulty.

-Oil pressure switch closes too lately. If oil pressure falls, the unit will start.

Optionally oil pressure switch may be replaced.

The engine does not run after the first start attempt, then the unit does not start again and the OIL PRESSURE ALARM led flashes:

-The oil pressure switch closes very lately. As the unit senses an oil pressure, it does not start. When oil pressure falls the unit will start. Optionally the oil pressure switch may be replaced.

When the AC mains fails, the engine starts to run but the unit gives FAIL TO START alarm and then the engine stops:

-The generator phase voltage is not connected to the unit. Measure the AC voltage between terminals (L1) and (Generator Neutral) at the rear of the unit while engine is running. The fuse protecting the generator phase may be failed. A misconnection may be occurred. If everything is OK, turn all the fuses off, and then turn all the fuses on, starting from the DC supply fuse. Then test the unit again.

The unit is late to remove engine cranking:

-The alternator voltage rises lately. Also the generator remanant voltage is below 10 volts. The unit removes starting with the generator frequency, and needs at least 10 volts to measure the frequency. If this situation is to be avoided, the only solution is to add an auxiliary relay. The coil of the relay will be between BATTERY (-) and charging alternator LAMP terminal. The normally closed contact of the relay will be connected serially to the unit's START output. So the starting will also be removed when the CHARGE LAMP turns off.

The unit is inoperative:

Measure the DC-supply voltage between (+) and (-) terminals at the rear of the unit. If OK, turn all the fuses off, then turn all the fuses on, starting from the DC supply fuse. Then try the unit again.

5. PROGRAMMING

The programming mode is used to program the timers, operational limits and the configuration of the unit.

To enter the program mode, press the PGM button. The display shows (Pr) when program mode is selected. When the MENU key is pressed the program number will be displayed, when it is released the program value will be shown. In this way all program parameters are accessed and the values can be increased or decreased by using (↑) and (↓) keys.

Programmed values are stored in a Non Volatile Memory, which is not affected by energy failures. **To exit programming**, press the OFF button.

P01=MAINS VOLTAGE LOWER LIMIT: If one of the mains phases goes under this limit, it means that the mains are off and it starts the transfer to the generator in automatic and test modes.

P02=MAINS VOLTAGE UPPER LIMIT: If one of the mains phases goes over this limit, it means that the mains are off and it starts the transfer to the generator in automatic and test modes.

P03=GENERATOR VOLTAGE LOWER LIMIT: If the generator phase voltage goes under this limit when feeding the load, this will mean a generator voltage failure and the engine will stop.

P04=GENERATOR VOLTAGE UPPER LIMIT: If the generator phase voltage goes over this limit when feeding the load, this will mean a generator voltage failure and the engine will stop.

P05=FREQUENCY LOWER LIMIT: If the generator frequency goes under this value, it causes an alarm after the frequency delay timer.

P06=FREQUENCY UPPER LIMIT: If the generator frequency goes over this value, it causes an alarm after the frequency delay timer.

P07=FREQUENCY DELAY: This is the period between the frequency goes out of the limits and an alarm occurs

P08=DC SUPPLY UPPER LIMIT: If DC Supply voltage exceeds this limit, it will cause DC Supply alarm after the 2 second delay and the diesel will stop. This alarm is particularly designed to prevent failure of the unit in case of charge alternator failure.

P09=NUMBER OF STARTS: Maximum number of start attempts.

P10=WAIT BEFORE START TIMER: Waiting period between the fuel on and start command.

P11=WAIT TIMER BETWEEN STARTS: Waiting period between two start attempts.

P12=START TIMER: Start period. Start will be automatically deactivated if the generator starts running before the timer.

P13=STOP TIMER: Stop solenoid activation timer. Enter 0 for an 'activate to start' type of engine.

P14=MAINS WAITING TIMER: This is the time between the mains voltages entered within the limits and the generator contactor is deactivated.

P15=COOLING TIMER: This is the period that the generator runs for cooling purpose after the load is transferred to mains.

P16=MAINS CONTACTOR TIMER: This is the period after the generator contactor has been deactivated and before the mains contactor has been activated.

P17=GENERATOR CONTACTOR TIMER: This is the period after the generator phases are within the limits and before the generator contactor has been activated.

P18=RELAY CONFIGURATION: FUEL and AUXILIARY relay configuration:

P18 VAL	AUX RELAY FUNCTION	FUEL RELAY FUNCTION
00	Alarm	Activate before Start
01	Fuel (Activate to Stop)	Activate before Start
02	Preheat	Activate before Start
03	Choke	Activate before Start
04	Alarm	Activate to Stop
05	Fuel (Activate to Stop)	Activate to Stop
06	Preheat	Activate to Stop
07	Choke	Activate to Stop

P19 = MAINTENANCE PERIOD (ENGINE HOURS): This is the engine periodic maintenance life as engine-hours

P20 = MAINTENANCE PERIOD (DURATION): This periodic maintenance limit (as months) must be observed even if the engine hours limit is not exceeded.

6. CALIBRATION

To enter the calibration mode, hold pressed the OFF button, then press PGM button. The rightmost decimal point of the voltage display will turn on. For following operations it is necessary to display the proper parameter by pressing the MENU key, and modify it by pressing using (↑) and (↓) keys. For more detailed explanation please refer to programming chapter of the user's manual.

P22: MAINS AND GENERATOR VOLTAGE DISPLAY CALIBRATION:

Connect mains phase voltages. Measure the voltage with a digital multimeter. (Between phase and neutral) Adjust P22 parameter until the unit displays the same voltage value as the multimeter. Check other phase voltages by pressing the MENU button in AUTO mode. (Max error=2volts)

P23: DC SUPPLY VOLTAGE DISPLAY CALIBRATION: Measure the DC Supply voltage with a digital multimeter. Adjust P23 parameter until the unit displays the same voltage value as the multimeter. (Max error=0.2volts)

7. TECHNICAL SPECIFICATIONS

Step Control : 8 bit microprocessor.

Mains Voltage: 277VAC (Ph-N)

Mains Frequency: 50/60Hz.

Power System Type: TN or TT.

Alternator Voltage: 277VAC (Ph-N)

Alternator Frequency: 0-100Hz.

Measurement Category: CAT II

DC Supply Range: 9.0 to 33.0 V-DC.

4.0 to 33.0 V-DC while cranking

Current Consumption: 100 mA-DC typical (AUTO, mains OK, 24volts)

250 mA-DC max. (Relay outputs open)

Total DC Current Output Rating: 10A-DC.

Total AC Current Output Rating: 10A-AC.

Current Rating for each Output Terminal: 10ARMS.

Data Port: Serial, logic levels (optional RS-232 levels).

Computer Host Program: MS-Windows

Operating Temperature Range: -20°C (-4°F) to 70 °C (158°F).

Storage Temperature Range: -30°C (-22°F) to 80 °C (176°F).

Maximum Humidity: 95% non-condensing.

Dimensions: 72 x 144 x 70mm (WxHxD)

Mounting Opening Dimensions: 140 x 68mm minimum.

Weight: 300 g (approx.)

Accuracy:

Phase voltages: 2% + 1 volt

Battery Voltage: 2% + 0.2 volts

Generator frequency: +/- 0.5 Hz

Case Material: Flame Retardant High Temperature ABS (UL94-V0, 110°C)

WARNING: Stresses exceeding above limits may result to a degradation of the unit's protection level.

8. DECLARATION OF CONFORMITY

The unit conforms to the EU directives

-73/23/EEC and 93/68/EEC (low voltage)

-89/336/EEC, 92/31/EEC and 93/68/EEC (electro-magnetic compatibility)

Norms of reference:

EN 61010 (safety requirements)

EN 50081-2 (EMC requirements)

EN 50082-2 (EMC requirements)

The CE mark indicates that this product complies with the European requirements for safety, health environmental and customer protection.

9. CONNECTION DIAGRAM

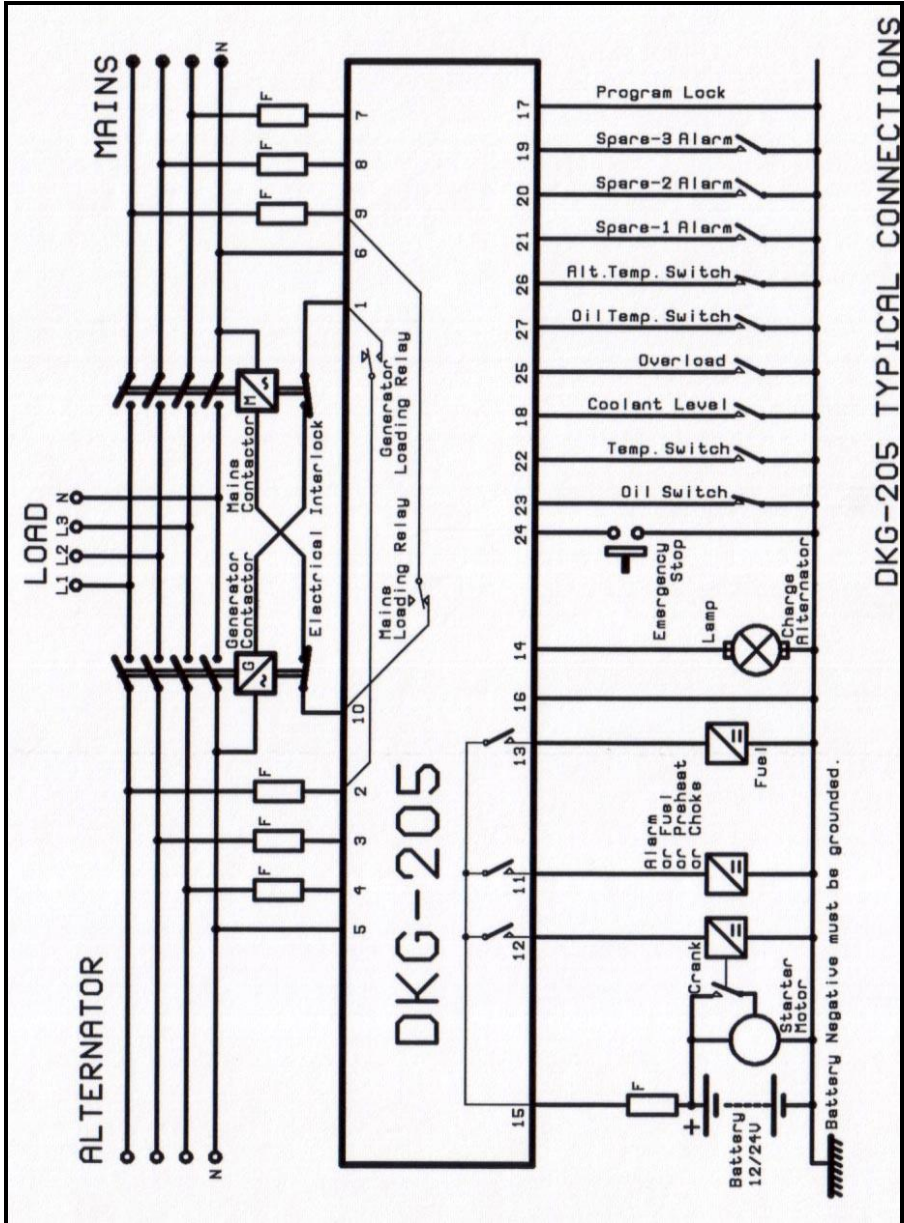

DATAKOM Electronics Limited

Tel : +90-216-466 84 60

Fax : +90-216-364 65 65

e-mail : datakom@datakom.com.tr

website: www.datakom.com.tr

DATAKOM reserves the right of making modifications to the unit without prior notice.